

# SELECTION GUIDE

# UTS800

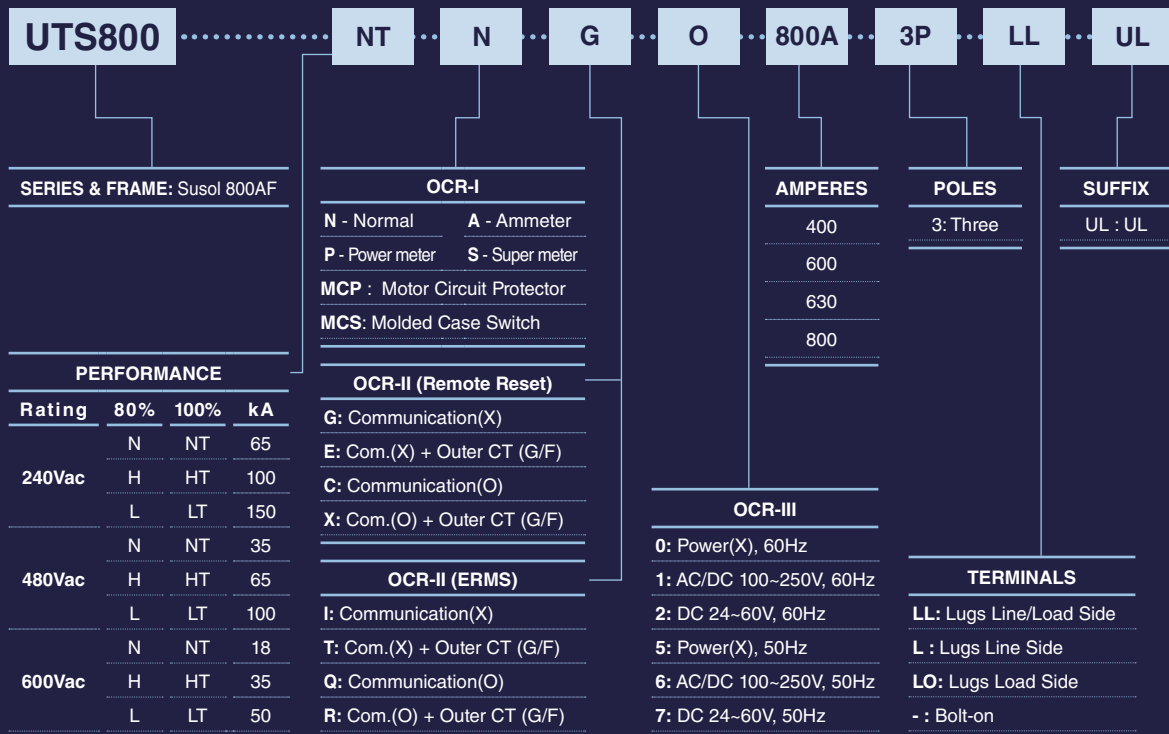

## CATALOG NUMBERING [PRODUCT SELECTION]



## UTS800 FRAME

UTS800 breaker is HACR rated

### UL489 RATINGS

BREAKER TYPE	NUMBER OF POLES	INTERRUPTING CAPACITY (kA rms) AC 50/60Hz		
		240V ac	480V ac	600V ac
UTS800N	3	65	35	18
UTS800H	3	100	65	35
UTS800L	3	150	100	50

### IEC60947-2 RATINGS

BREAKER TYPE	NUMBER OF POLES	INTERRUPTING CAPACITY(kA rms) AC 50/60Hz, Icu			RATED SHORT-TIME WITHSTAND CURRENT (Icw)	UTILIZATION CATEGORY
		220/240V	380/415V	480/500V		
UTS800N	3	65	35	18	18kA	B
UTS800H	3	100	65	35	-	A
UTS800L	3	150	100	50	-	A
Service breaking capacity, Ics (%Icu)				100%		
Insulation Voltage, Ui				1000 Vac		
Impulse Withstand Voltage, Uimp				8 kVac		

### DIMENSIONS

POLE	DIMENSIONS inch (mm)		
	W	H	D
3-Pole	8.27 (210)	12.88 (327.2)	6 (152.5)

### CIRCUIT BREAKER

WITH N (NORMAL) TYPE TRIP UNIT				
Ampere Rating, In	65kA at 240V, 35kA at 480V, 18kA at 600V	100kA at 240V, 65kA at 480V, 35kA at 600V	150kA at 240V, 100kA at 480V, 50kA at 600V	Remarks
	3-Pole	3-Pole	3-Pole	
400A	UTS800-N-N●■-400-3	UTS800-H-N●■-400-3	UTS800-L-N●■-400-3	Long time delay / Short time delay Instantaneous / Ground faults / Self power ※ LCD/SMPS is Removed from A type
600A	UTS800-N-N●■-600-3	UTS800-H-N●■-600-3	UTS800-L-N●■-600-3	
630A	UTS800-N-N●■-630-3	UTS800-H-N●■-630-3	UTS800-L-N●■-630-3	
800A	UTS800-N-N●■-800-3	UTS800-H-N●■-800-3	UTS800-L-N●■-800-3	

WITH A (AMMETER) TYPE TRIP UNIT				
Ampere Rating, In	65kA at 240V, 35kA at 480V, 18kA at 600V	100kA at 240V, 65kA at 480V, 35kA at 600V	150kA at 240V, 100kA at 480V, 50kA at 600V	Remarks
	3-Pole	3-Pole	3-Pole	
400A	UTS800-N-A●■-400-3	UTS800-H-A●■-400-3	UTS800-L-A●■-400-3	All function of N type / Earth Leakage (Except residual current) ZSI / Comm. (Modbus, Profibus) AC/DC 100-250V / DC 24-60V Fault Recording 10ea
600A	UTS800-N-A●■-600-3	UTS800-H-A●■-600-3	UTS800-L-A●■-600-3	
630A	UTS800-N-A●■-630-3	UTS800-H-A●■-630-3	UTS800-L-A●■-630-3	
800A	UTS800-N-A●■-800-3	UTS800-H-A●■-800-3	UTS800-L-A●■-800-3	

WITH P (POWER METER) TYPE TRIP UNIT				
Ampere Rating, In	65kA at 240V, 35kA at 480V, 18kA at 600V	100kA at 240V, 65kA at 480V, 35kA at 600V	150kA at 240V, 100kA at 480V, 50kA at 600V	Remarks
	3-Pole	3-Pole	3-Pole	
400A	UTS800-N-P●■-400-3	UTS800-H-P●■-400-3	UTS800-L-P●■-400-3	All function of A type (UV/OV/OF/UF/RV/Vun/Cun) <sup>a)</sup> Measuring (V/A/W/P/F/PF) <sup>b)</sup> Fault Recording 256ea/ Event Recording 256ea
600A	UTS800-N-P●■-600-3	UTS800-H-P●■-600-3	UTS800-L-P●■-600-3	
630A	UTS800-N-P●■-630-3	UTS800-H-P●■-630-3	UTS800-L-P●■-630-3	
800A	UTS800-N-P●■-800-3	UTS800-H-P●■-800-3	UTS800-L-P●■-800-3	

Note :

a) UV: Under Voltage // OV: Over Voltage // OF: Over Frequency // UF: Under Frequency // RV: Reverse power // Vun: Voltage Unbalance // Cun: Current Unbalance

b) V: Voltage // A: Ampere // W: Watt // P: Power // F: Frequency // PF: Power factor

●: OCR-II, ■: OCR-III

## UTS800 FRAME

### CIRCUIT BREAKER

WITH S (SUPER METER) TYPE TRIP UNIT				
Ampere Rating, In	65kA at 240V, 35kA at 480V, 18kA at 600V	100kA at 240V, 65kA at 480V, 35kA at 600V	150kA at 240V, 100kA at 480V, 50kA at 600V	Remarks
	3-Pole	3-Pole	3-Pole	S(super meter) type trip unit *1
400A	UTS800-N-S●■-400-3	UTS800-H-S●■-400-3	UTS800-L-S●■-400-3	All function of P type Display Harmonics and wave forms
600A	UTS800-N-S●■-600-3	UTS800-H-S●■-600-3	UTS800-L-S●■-600-3	
630A	UTS800-N-S●■-630-3	UTS800-H-S●■-630-3	UTS800-L-S●■-630-3	
800A	UTS800-N-S●■-800-3	UTS800-H-S●■-800-3	UTS800-L-S●■-800-3	

Note \*1 : The range of rated current setting is same with 4 Types but P/S type is able to set detail adjustment of rated current per 1A ( Fine Adjustable )

### MOLDED CASE SWITCH

WITH MCS TRIP UNIT (FIXED MAGNETIC ONLY)				
Ampere Rating, In	65kA at 240V, 35kA at 480V, 18kA at 600V	100kA at 240V, 65kA at 480V, 35kA at 600V	150kA at 240V, 100kA at 480V, 50kA at 600V	Remarks
	3-Pole	3-Pole	3-Pole	MCS type trip unit
800A	UTS800-N-MCS●■-800-3	UTS800-H-MCS●■-800-3	UTS800-L-MCS●■-800-3	Magnetic range : 12000A fixed

### MOTOR CIRCUIT PROTECTOR

WITH MCP TRIP UNIT (ADJUSTABLE MAGNETIC ONLY)				
Ampere Rating, In	3-Pole	3-Pole	3-Pole	Remarks
	MCP type trip unit			
800A	UTS800-N-MCP●■-800-3	UTS800-H-MCP●■-800-3	UTS800-L-MCP●■-800-3	Magnetic range : 2~12In

ITEM	SETTING RANGE
<b>Ir</b> (rated current)	0.4~1.0 In
<b>Tr</b> (long time tripping delay)	0.5~20 (s)
<b>Isd</b> (short time current)	1.5~10 Ir
<b>Tsd</b> (short time tripping delay)	0.05~0.4 (s)

ITEM	SETTING RANGE
<b>Ii</b> (instantaneous current)	2~15 In
<b>Tg</b> (ground fault tripping delay)	0.05~0.4 (s)
<b>Ig</b> (ground fault current)	0.2~1In

●	OCR-II (Remote Reset)	OCR-II (ERMS)
	<b>G:</b> Communication(X)	<b>I:</b> Communication(X)
	<b>E:</b> Com.(X)+Outer CT(G/F)	<b>T:</b> Com.(X)+Outer CT(G/F)
	<b>C:</b> Communication(O)	<b>G:</b> Communication(O)
	<b>X:</b> Com.(O)+Outer CT(G/F)	<b>R:</b> Com.(O)+Outer CT(G/F)

■	OCR-III
	<b>0:</b> Power(X), 60Hz
	<b>1:</b> AC/DC 100~250V, 60Hz
	<b>2:</b> DC 24~60V, 60Hz
	<b>5:</b> Power(X), 50Hz
	<b>6:</b> AC/DC 100~250V, 50Hz
	<b>7:</b> DC 24~60V, 50Hz

## ACCESSORIES FOR UTS800

### MECHANICAL LUGS

MAXIMUM BREAKER AMPERES	TERMINAL BODY MATERIAL	WIRE TYPE	ORDERING TYPE
800A	Aluminum	Cu/Al	AL800TS

AL800TS 400-800A Lug

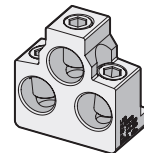

### INNER ACCESSORIES

DESCRIPTION	CONTROL VOLTAGE	ORDERING TYPE
Auxiliary Switch, AX		
Alarm Switch, AL		
Shunt Trip, SHT	DC 24-30V	
	AC 48V/DC 48-60V	
	AC/DC 100-130V	
	AC/DC 200-250V	
Undervoltage Trip, UVT	AC 380-480V	
	DC 24-30V	
	AC 48V/DC 48-60V	
	AC/DC 100-130V	
Undervoltage Trip, UVT	AC/DC 200-250V	
	AC 380-480V	

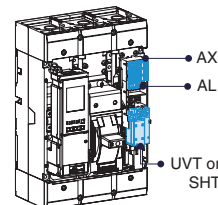

Type	Right(T)
AX	3
AL	1
SHT	1*
UVT	1*

\* Applicable in indicated pole position-not synchronous

### PADLOCKING DEVICE

DESCRIPTION	ORDERING TYPE
Lock in "OFF" position	PL5



<Pad Lock>

### PLATE HANDLE LOCKING DEVICE

DESCRIPTION	ORDERING TYPE
Lock in "OFF" or "ON" position	PHL5



<Plate Handle Lock>

### MECHANICAL INTERLOCKING DEVICE

DESCRIPTION	ORDERING TYPE
For 3-Pole breaker	MIT53



<Mechanical Interlock>

## ACCESSORIES FOR UTS800

### ENCLOSURE

ENCLOSURE DIMENSION (W X H X D) inch (mm)	ORDERING TYPE
20.25 (514.4) x 51.9 (1318.3) x 7.75 (196.9)	-

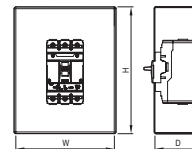

### INSULATION BARRIERS

DESCRIPTION	QTY PER KIT	ORDERING TYPE
Standard type	2	B53
Extended type	2	BE53

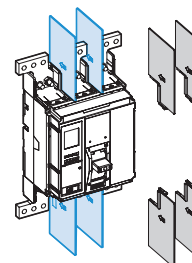

### ROTARY OPERATING HANDLES

DESCRIPTION	TYPE	ORDERING TYPE
Directly Mounted	NEMA Type 1	DH-5
Directly Mounted (with Key lock)	NEMA Type 1	DHK-5
Extended (Door-Mounted)	NEMA Type 1	REH-5
	NEMA Type 1, 12	EHU-5
NEMA Door-Mounted	NEMA Type 3, 3R, 4	EHV-5
	NEMA Type 3, 4, 4X	EHX-5

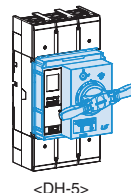

<DH-5>

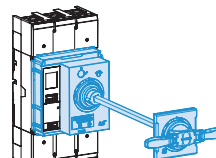

<REH-5>

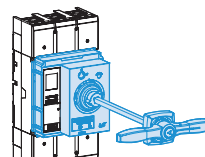

<EHU-5>

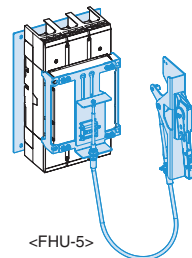

<FHU-5>

### FLANGE OPERATING HANDLES

DESCRIPTION	TYPE	ORDERING TYPE
Handles (Including driving part/ excluding cable)	NEMA Type 1, 12, 3, 3R, 4	FHU-5
	NEMA Type 4, 4X	FHX-5
Cable	60 inch	FH5-60
	84 inch	FH5-84
	128 inch	FH5-128

**FLANGE HANDLES WITH CABLE OPERATING MECHANISM**

DESCRIPTION	TYPE	ORDERING TYPE
Cable operating mechanism (without cable)		COM-5
Long type handle (with operating mechanism)	NEMA Type 1, 12, 3, 3R, 4	FHU-L
	NEMA Type 4, 4X	FHX-L
Cable	60 inch	FH5-60
	84 inch	FH5-84
	128 inch	FH5-128

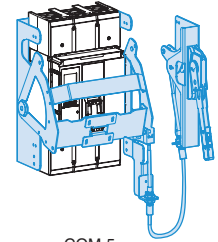

<COM-5>

**FLANGE HANDLES WITH VARIABLE-DEPTH OPERATING MECHANISM**

Description	Type	Ordering type
Variable depth operating mechanism with threaded-rod and handle		VDM-5
Long type handle (with operating mechanism)	NEMA Type 1, 12, 3, 3R, 4	FHU-L
	NEMA Type 4, 4X	FHX-L

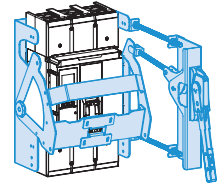

<VDM-5>

TYPE	DIRECTLY MOUNTED	DOOR MOUNTED	FLANGE HANDLE WITH CABLE/SLIDING OPERATION MECHANISM	FLANGE HANDLE WITH VARIABLE DEPTH MECHANISM
NEMA TYPE 1			-	-
NEMA Type 1, 12, 3, 3R, 4, 4X	-			

# MCCB FOR UL489 DC APPLICATION



Frame		UTE100		UTE100		UTS150			UTS250		
Maximum Rated Current		100A		100A		150A			250A		
Number of Poles		2		3		2, 3			2, 3		
Breaker Type		E	N	E	N	N	H	L	N	H	L
<b>UL489 DC</b>		<b>UTE100</b>		<b>UTE100</b>		<b>UTS150</b>			<b>UTS250</b>		
Interrupting Capacity (kA) DC UL, CSA	250V dc-2P	16	25	16	25	35	50	65	35	50	65
	500V dc-3P	-	-	25	35	-	-	-	-	-	-
	600V dc-3P	-	-	-	-	35	50	65	35	50	65
TRIP UNITS	Amperes	15~100A		15~100A		40~150A			150~250A		
F : Fixed	ATU	-		-		●			●		
A : Adjustable	FMU	-		●		●			●		
T : Thermal	FTU	●		●		●			●		
M : Magnetic	Amperes	100A		100A		150A			250A		
MCS	MCS	●		●		●			●		
Unit Mounted		●		●		●			●		
Mechanical Lugs		●		●		●			●		
Busbar connectors		●		●		●			●		
Control Wire Terminal Kit		-		-		●			●		
Terminal Shields		-		-		-			-		
Interphase Barriers		●		●		●			●		
Shunt Trip		●		●		●			●		
Undervoltage Trip		●		●		●			●		
Auxiliary Switch		●		●		●			●		
Alarm Switch		●		●		●			●		
Flange Cable Handle		●		●		●			●		
Flange Variable-Depth Mechanism		●		●		●			●		
Directly-Mounted Rotary Operating Handle		-		●		●			●		
NEMA-Door-Mounted Operating Mechanisms		●		●		●			●		
IEC-Door-Mounted Operating Mechanisms		●		●		●			●		
Mechanical Interlocks		-		●		●			●		
Handle Padlock Attachment		●		●		●			●		
Weight(approximate) lbs.(kg)	2-Pole	1.64(0.74)		-		3.44(1.56)			3.88(1.76)		
	3-Pole	-		2.33(1.06)		3.95(1.79)			4.49(2.04)		
Dimensions Inches(mm)	poles	<b>W</b>	<b>H</b>	<b>D</b>	<b>W</b>	<b>H</b>	<b>D</b>	<b>W</b>	<b>H</b>	<b>D</b>	
	2-Pole	2.01(51)	5.12(130)	3.44(87.5)	4.13(105)	6.50(165)	3.44(87.5)	4.13(105)	7.48(190)	3.44(87.5)	
	3-Pole	2.99(76)	5.12(130)	3.44(87.5)	4.13(105)	6.50(165)	3.44(87.5)	4.13(105)	7.48(190)	3.44(87.5)	

Note1) TS800U 700A: Only FTU



# ACCESSORIES

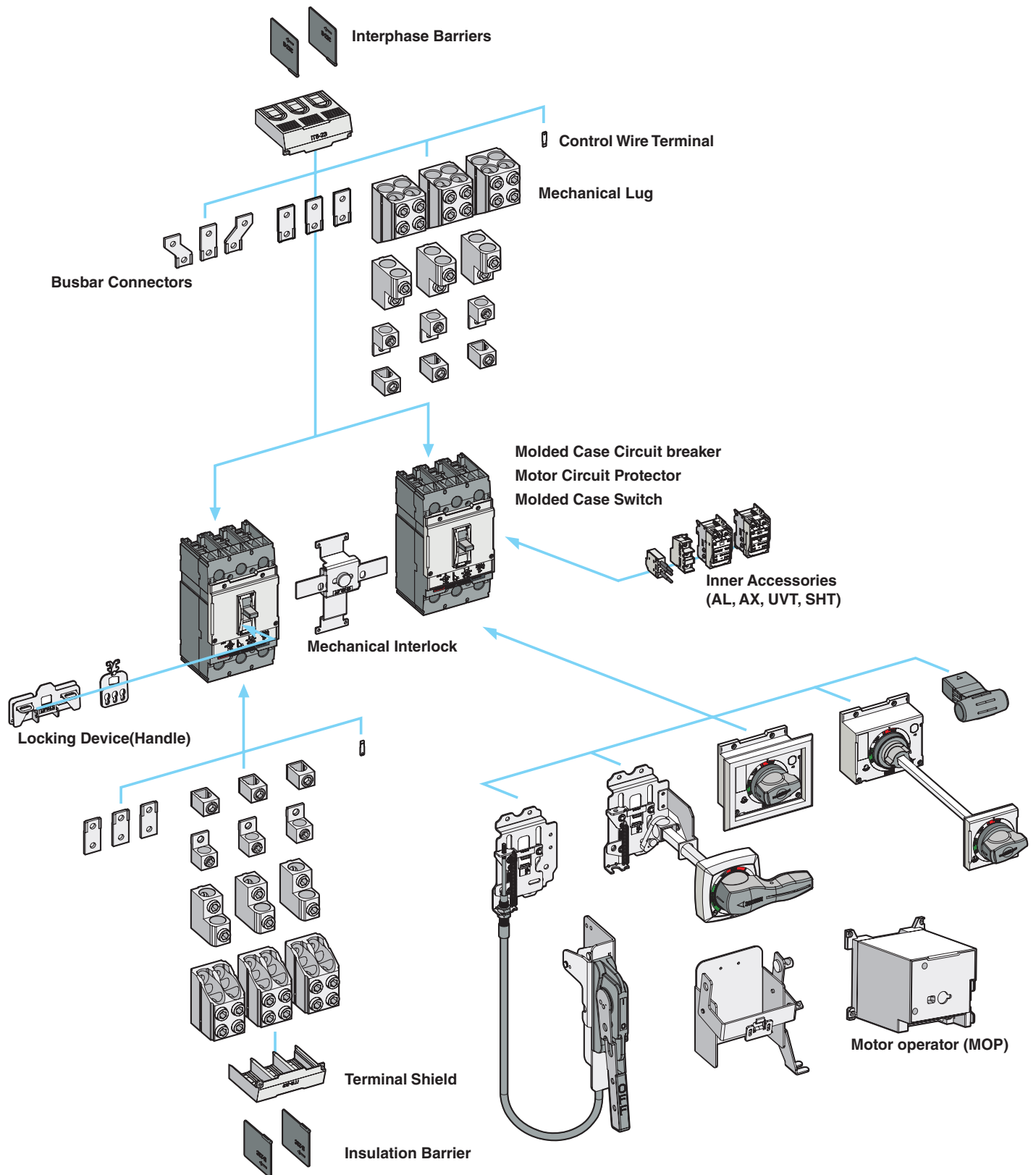

## MECHANICAL LUG OVERVIEW

UTE100 to UTS1200 frame circuit breakers can be ordered with mechanical line and load side lugs. The standard lugs can be removed for the installation of bus connections. All lugs are UL/cUL Listed Certified for their proper application and marked for use with aluminum and copper (Al/Cu) or copper only (Cu) conductors. Lugs suitable for copper and aluminum conductors are made of tin-plated aluminum. Mechanical lugs are sold either factory installed or as field installable kits.

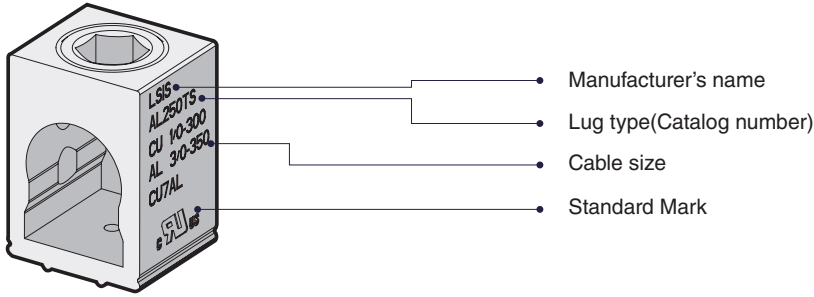

### MECHANICAL LUG KITS FOR UTE100 CIRCUIT BREAKERS

LUG TYPE	TERMINAL BODY MATERIAL	WIRE TYPE	BREAKER AMP RANGE	APPLICABLE WIRE (AWG)	TORQUE N-m (lb-in)
AL 100TE	Aluminum	60 °C	15~30A	14~10	3.6 (31.9)
			40A	8	4.5 (39.8)
			50~80A	6~3	5.4 (47.8)
		75 °C	90~100A	2~1	6.3 (55.8)
			15~30A	14~10	3.6 (31.9)
			40~50A	8	4.5 (39.8)
	AL	60 °C	60~100A	6~3	5.4 (47.8)
			40~60A	6~3	5.4 (47.8)
			70~80A	2~1	6.3 (55.8)
		75 °C	50~70A	6~3	5.4 (47.8)
			80~100A	2~1/0	6.3 (55.8)

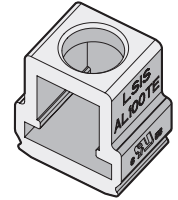

**AL100TE**  
15~100A LUG

### MECHANICAL LUG KITS FOR UTS150 CIRCUIT BREAKERS

LUG TYPE	TERMINAL BODY MATERIAL	BREAKER AMP RANGE	WIRE TYPE	APPLICABLE WIRE (AWG)	TORQUE N-m (lb-in)
AL150TS	Aluminum	1.6~15A	Cu	14	4.1 (36.2)
		20~30A	Cu	12~10	5.4 (47.8)
		40~175A	Cu	8~2/0	15.1 (133.6)
		50~70A	Al	6~3	5.4 (47.8)
		90~150A	Al	2~3/0	15.7 (138.6)

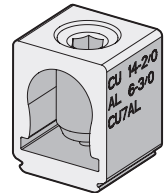

**AL150TS**  
1.6~150A LUG

## MECHANICAL LUG OVERVIEW

### MECHANICAL LUG KITS FOR UTS250 CIRCUIT BREAKERS

LUG TYPE	TERMINAL BODY MATERIAL	BREAKER AMP RANGE	WIRE TYPE	APPLICABLE WIRE (AWG)	TORQUE N·m (lb-in)
AL250TS	Aluminum	150~175A	Cu	1/0~2/0 AWG	32 (283.2)
		150~175A (Al) 200~225A (Cu)	Cu/Al	3/0~4/0 AWG	
		200~225A (Al) 250A (Cu)	Cu/Al	250~300kcmil	44 (389.4)
		250A	Al	350kcmil	

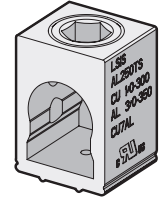

**AL250TS**  
150~250A LUG

### MECHANICAL LUG KITS FOR UTS400 CIRCUIT BREAKERS

LUG TYPE	TERMINAL BODY MATERIAL	BREAKER AMP RANGE	WIRE TYPE	APPLICABLE WIRE (AWG)	TORQUE N·m (lb-in)
AL400TS	Aluminum	250A 300A 350A 400A	Cu/Al	1/0AWG ~300kcmil	40.5 (358.5)
			Cu/Al	350~600kcmil	54 (478)
			Al *	700~750kcmil	54 (478)

\* Compact wire only (700~750kcmil)

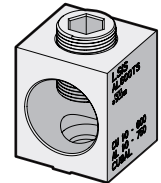

**AL400TS**  
250~400A LUG

### MECHANICAL LUG KITS FOR UTS600 CIRCUIT BREAKERS

LUG TYPE	TERMINAL BODY MATERIAL	BREAKER AMP RANGE	WIRE TYPE	APPLICABLE WIRE (AWG)	TORQUE N·m (lb-in)
AL600TS	Aluminum	500A 600A	Cu	2/0AWG ~350kcmil	40.5 (358.5)
			Al *	3/0AWG ~500kcmil	40.5 (358.5)

\* Compact wire only (400~500kcmil)

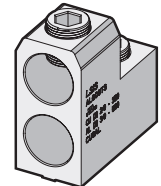

**AL600TS**  
500~600A LUG

### MECHANICAL LUG KITS FOR UTS800 CIRCUIT BREAKERS

LUG TYPE	TERMINAL BODY MATERIAL	BREAKER AMP RANGE	WIRE TYPE	APPLICABLE WIRE (AWG)	TORQUE N·m (lb-in)
AL800TS	Aluminum	400A 600A 630A 800A	Cu	3/0AWG ~300kcmil	45 (398.3)
			Al *	3/0AWG ~400kcmil	45 (398.3)

\* Compact wire only (350~400kcmil)

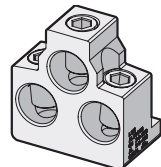

**AL800TS**  
400~800A LUG

### MECHANICAL LUG KITS FOR UTS1200 CIRCUIT BREAKERS

LUG TYPE	TERMINAL BODY MATERIAL	BREAKER AMP RANGE	WIRE TYPE	APPLICABLE WIRE (AWG)	TORQUE N·m (lb-in)
AL1200TS	Aluminum	800A 1000A 1200A	Cu	3/0AWG ~350kcmil	45 (398.3)
			Al *	3/0AWG ~500kcmil	45 (398.3)

\* Compact wire only (400~500kcmil)

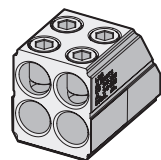

**AL1200TS**  
800~1200A LUG

## INTERNAL ACCESSORIES OVERVIEW

Field-installable accessories provide flexibility for installation at the point of use. Auxiliary switches, alarm switches, shunt trip, and undervoltage release accessories are easy to install, reliable, and common to all Susol molded case circuit breakers. The internal accessories comply with requirements of Underwriters Laboratories® Inc. UL 489 Standards

### ACCESSORY LOCATIONS

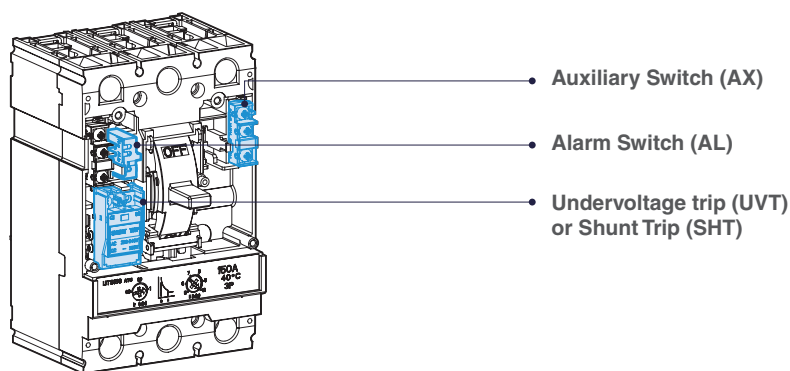

FRAME	INTERNAL ACCESSORIES LOCATIONS	TYPE	LEFT(R)	RIGHT(T)
UTE100	<p>* 2P : Right only</p> <ul style="list-style-type: none"> <li>AX or AL or AX+AL</li> <li>UVT or SHT or AX or AL or AX+AL</li> </ul>	AX	1*	1*
		AL	1*	1*
		AX+AL	1*	1*
		SHT	-	1*
		UVT	-	1*
UTS150 UTS250	<ul style="list-style-type: none"> <li>AX</li> <li>AX</li> <li>AL</li> <li>UVT or SHT</li> </ul>	AX	1	1
		AL	1	-
		SHT	1*	-
		UVT	1*	-
		UVT or SHT	1*	-
UTS400 UTS600	<ul style="list-style-type: none"> <li>AX</li> <li>AL</li> <li>UVT or SHT</li> </ul>	AX	3	-
		AL	-	1
		SHT	1*	-
		UVT	1*	-
UTS800 UTS1200	<ul style="list-style-type: none"> <li>AX</li> <li>AL</li> <li>UVT or SHT</li> </ul>	AX	-	3
		AL	-	1
		SHT	-	1*
		UVT	-	1*

\* Applicable in indicated pole position-not synchronous

### ACCESSORY CONNECTIONS

Electrical accessories are fitted with numbered terminal blocks for wires. Auxiliary circuit wiring exits fixed mounted devices through a knock-out in the front cover. The internal accessories comply with requirements of Underwriters Laboratories® Inc. UL 489 Standards

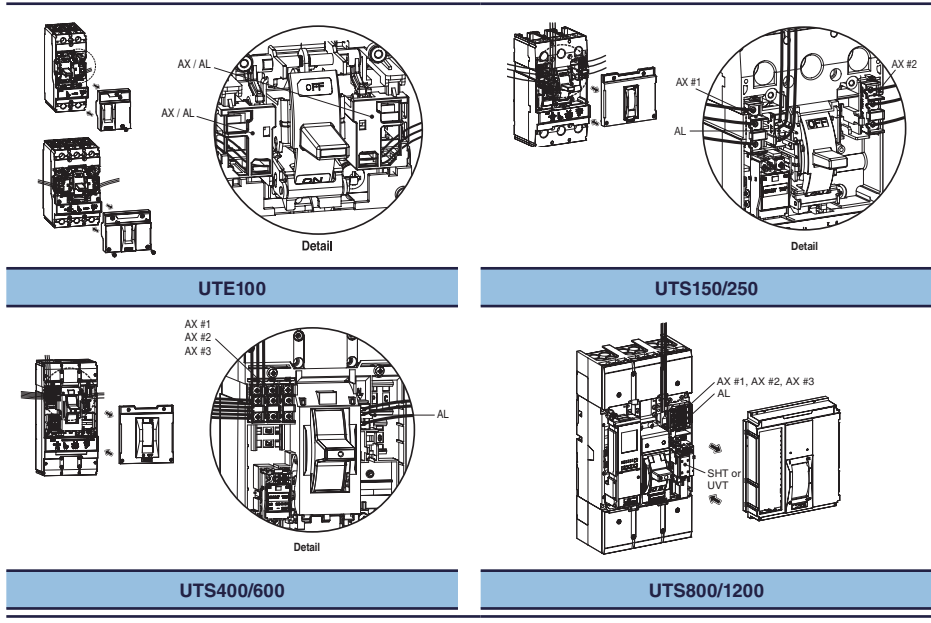

### AUXILIARY SWITCH (AX) AND ALARM SWITCH (AL)

Auxiliary switches provide remote information of the circuit breaker status and can be used for indications, electrical locking, relays, etc.

#### AUXILIARY SWITCH (AX):

Indicates the position of the circuit breaker contacts(Open/Closed)  
Auxiliary switch is for applications requiring remote “ON” and “OFF” indication.  
Each switch contains two contacts having a common connection.  
One is open and the other closed when the circuit breaker is open, and vice-versa.

AX	BREAKER TYPE	WIRE SIZE	ON	OFF/TRIP
	UTE100	24 AWG (0.2 mm <sup>2</sup> )		
	UTS150 UTS250 UTS400 UTS600	20 AWG (0.52 mm <sup>2</sup> )		
	UTS800 UTS1200	19~16 AWG (0.65~1.31 mm <sup>2</sup> )		

### ALARM SWITCH (AL):

Alarm switches indicate that the circuit breaker has tripped due to an overload, short circuit, shunt trip, or undervoltage trip or the “push-to-trip” button.

They are particularly useful in automated plants where operators must be signaled about changes in the electrical distribution system. This switch features a closed contact when the circuit breaker is tripped automatically. In other words, this switch does not function when the breaker is operated manually. Its contact is open when the circuit breaker is reset.

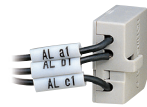
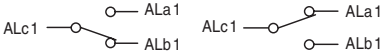
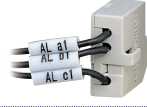
AL	BREAKER TYPE	WIRE SIZE	ON/OFF	TRIP
	UTE100	24 AWG (0.2 mm <sup>2</sup> )		
	UTS150 UTS250 UTS400 UTS600	26 AWG (0.13 mm <sup>2</sup> )		
	UTS800 UTS1200	24 AWG (0.2 mm <sup>2</sup> )		

### FAULT ALARM SWITCH (FAL):

FAL Indicates that the breaker has tripped due to overload or short circuit. And, it can be applied to only circuit breakers with electronic trip units.

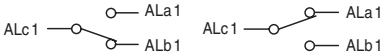
FAL	BREAKER TYPE	WIRE SIZE	ON/OFF	TRIP
	UTS150 UTS250 UTS400 UTS600	26 AWG (0.13 mm <sup>2</sup> )		

### TECHNICAL DATA

Conventional thermal current I <sub>th</sub>	5A				
Rated operational current I <sub>e</sub>	Voltage	I <sub>e</sub>		Minimum load current	
with rated operational voltage U <sub>e</sub>		Resistance	Inductance		
- Alternating current 50/60Hz AC	125V	5	3	5V DC 160mA 30V DC 30mA	UTE100
	250V	3	2		UTS150
	500V	-	-		UTS250 UTS400
- Direct current DC	30V	4	3		UTS600
	125V	0.4	0.4		UTS800
	250V	0.2	0.2		UTS1200

### SHUNT TRIP (SHT) AND UNDERVOLTAGE TRIP (UVT) SWITCHES

A voltage release can be used to trip the circuit breaker via a control signal.

#### SHUNT TRIP (SHT):

The shunt trip opens the mechanism in response to an externally applied voltage signal. The releases include coil clearing contacts that automatically clear the signal circuit when the mechanism has tripped.

#### UTE100 SHT

CONTROL VOLTAGE, U <sub>e</sub>		POWER CONSUMPTION		
		AC (VA)	DC (W)	mA
VOLTAGE	AC/DC 12V	0.35	0.36	30
	AC/DC 24V	0.64	0.65	27
	AC/DC 48V	1.09	1.1	23
	AC/DC 60V	1.2	1.22	20
	AC/DC 100~130V	0.73	0.75	5.8
	AC/DC 200~250V	1.21	1.35	5.4
	AC 380~450V	1.67	-	3.8
	AC 440~500V	1.68	-	3.5
Max.opening time		50ms (max.)		
Tightening torque of terminal screw		7.12 lb-in (0.8N-m)		
Operating voltage range		AC : 0.7~1.1V <sub>n</sub> , DC : 0.8~1.1V <sub>n</sub>		
Frequency		45Hz ~ 65 Hz (Only AC)		
Wire size		20 AWG (0.52 mm <sup>2</sup> )		



UTE100 SHT

#### UTS150/250/400/600 SHT

CONTROL VOLTAGE, U <sub>e</sub>		POWER CONSUMPTION		
		AC (VA)	DC (W)	mA
VOLTAGE	DC 12V	-	0.36	30
	AC/DC 24V	0.58	0.58	24
	AC/DC 48V	1.22	1.23	25
	AC/DC 110~130V	1.36	1.37	10.5
	AC 220~240V/DC 250V	1.8	1.88	7.5
	AC 380~500V	1.15	-	2.3
Max.opening time		50ms (max.)		
Tightening torque of terminal screw		7.12 lb-in (0.8N-m)		
Operating voltage range		0.7~1.1V <sub>n</sub>		
Frequency		45Hz ~ 65 Hz (Only AC)		
Wire size		20 AWG (0.52 mm <sup>2</sup> )		



UTS150/250/400/600 SHT

#### UTS800/1200 SHT

CONTROL VOLTAGE, U <sub>e</sub>		OPERATING VOLTAGE RANGE	POWER CONSUMPTION (VA or W)	
			INRUSH	STEADY-STATE
VOLTAGE	DC 24~30V	0.6~1.1V <sub>n</sub>	200	5
	AC 48V/DC 48~60V	0.6~1.1V <sub>n</sub>		
	AC/DC 100~130V	0.56~1.1V <sub>n</sub>		
	AC/DC 200~250V	0.56~1.1V <sub>n</sub>		
	AC 380~480V	0.56~1.1V <sub>n</sub>		
Max.opening time		40ms (max.)		
Frequency		45Hz~65Hz (Only AC)		
Wire size		16 AWG (1.31mm <sup>2</sup> )~14 AWG (2.08mm <sup>2</sup> )		



UTS800/1200 SHT

## UNDERVOLTAGE TRIP (UVT) :

The undervoltage release automatically opens a circuit breaker when voltage drops to a setting value of the line voltage. The operation is instantaneous, and after tripping, the circuit breaker cannot be re-closed again until the voltage returns to a recover value of line voltage.

Continuously energized, the undervoltage release must be operating before the circuit breaker can be closed.

### UTE100 UVT

CONTROL VOLTAGE, U <sub>e</sub>		POWER CONSUMPTION		
		AC (VA)	DC (W)	mA
VOLTAGE	AC/DC 24V	0.64	0.65	27
	AC/DC 48V	1.09	1.1	23
	AC/DC 100~110V	0.73	0.75	5.8
	AC/DC 200~220V	1.21	1.35	5.4
	AC 380~440V	1.67	-	3.8
	AC 440~480V	1.68	-	3.5
Max.opening time		50ms (max.)		
Tightening torque of terminal screw		7.12 lb-in (0.8N-m)		
Operating voltage range	Trip	0.2~0.7Vn		
	Reset/Closing	≥ 0.85Vn		
Frequency		45Hz ~ 65Hz (Only AC)		
Wire size		20 AWG (0.52 mm <sup>2</sup> )		

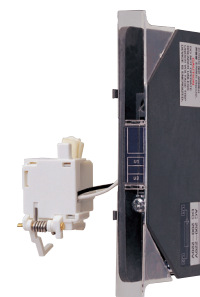

UTE100 UVT

### UTS150/250/400/600 UVT

CONTROL VOLTAGE, U <sub>e</sub>		POWER CONSUMPTION		
		AC (VA)	DC (W)	mA
VOLTAGE	AC/DC 24V	0.64	0.65	27
	AC/DC 48V	1.09	1.1	23
	AC/DC 110~130V	0.73	0.75	5.8
	AC 220~240V/DC 250V	1.21	1.35	5.4
	AC 380~440V	1.67	-	3.8
	AC 440~480V	1.68	-	3.5
Max.opening time		50ms (max.)		
Tightening torque of terminal screw		7.12 lb-in (0.8N-m)		
Operating voltage range	Trip	0.35~0.7Vn		
	Reset/Closing	≥ 0.85Vn		
Frequency		45Hz ~ 65 Hz (Only AC)		
Wire size		20 AWG (0.52 mm <sup>2</sup> )		



UTS150/250/400/600 UVT

### UTS800/1200 UVT

CONTROL VOLTAGE, U <sub>e</sub>		POWER CONSUMPTION (VA or W)		MAX.OPENING TIME (ms)
		INRUSH	STEADY-STATE	
VOLTAGE	DC 24~30V	200	5	50ms (max.)
	AC 48V/DC 48~60V			
	AC/DC 100~130V			
	AC/DC 200~250V			
	AC 380~480V			
Operating voltage range	Trip	0.44~0.6Vn		
	Reset/Closing	0.65~0.85Vn		
Frequency		45Hz~65Hz (Only AC)		
Wire size		16 AWG (1.31mm <sup>2</sup> )~ 14 AWG (2.08mm <sup>2</sup> )		



UTS800/1200 UVT

## LOCKING SYSTEMS OVERVIEW

### PADLOCKING DEVICE

Padlocking device is available for UTE100 to UTS1200 circuit breakers. The locking device is designed to be easily attached to the circuit breaker. This device allows the handle to be locked in the “OFF” position. The locking device for the toggle handle can be installed in circuit breakers. Maximum three (3) padlocks with shackle diameters of 0.19~0.31 in. (5~8mm) may be used. (Padlocks are not supplied.)

DESCRIPTION	CIRCUIT BREAKERS	FUNCTION
PL0	UTE100	Lock in “OFF” position
PL2	UTS150/250	
PL3	UTS400/600	
PL5	UTS800/1200	

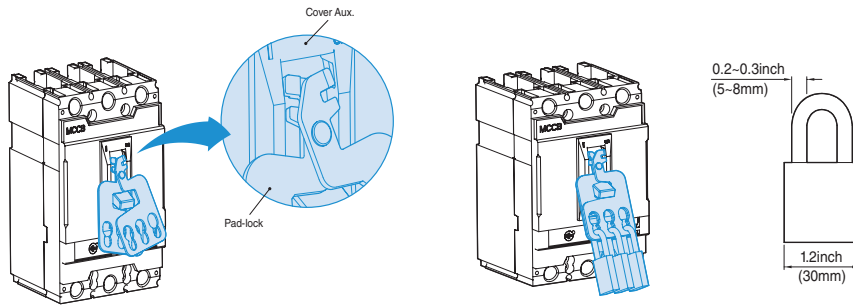

Pad Lock

### PLATE HANDLE LOCKING DEVICE

Fixed Plate Handle locking device is available for to UTE100 from UTS1200 circuit breakers. This device allows the handle to be locked in the “ON” and “OFF” position. The locking device for the toggle handle can be installed in 2-pole and 3-pole circuit breakers. Maximum three (3) padlocks with shackle diameters ranging from 0.19 to 0.31in (5~8mm) may be used. (Plate handle locks are not supplied)

DESCRIPTION	CIRCUIT BREAKERS	FUNCTION
PHL0	UTE100	Lock in “OFF” or “ON” position
PHL2	UTS150/250	
PHL3	UTS400/600	
PHL5	UTS800/1200	

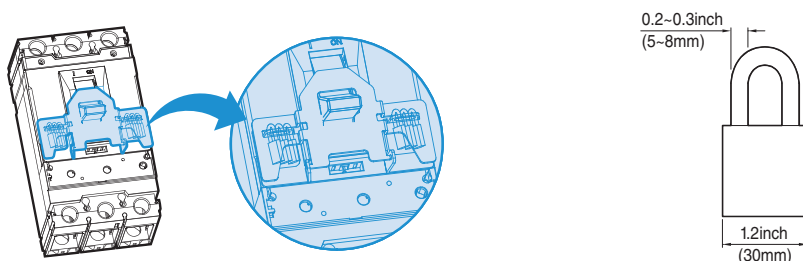

Plate Handle Lock

## INTERLOCKING SYSTEMS OVERVIEW

### MECHANICAL INTERLOCKING DEVICE

The mechanical interlock (MIT) can be applied on the front of two breakers mounted side by side, in either the 2-pole or 3-pole version and prevents simultaneous closing of the two breakers. Fixing is carried out directly on the cover of the breakers. The front interlocking plate allows installation of a padlock in order to fix the position. (Possibility of locking in the O-O position as well) This mechanical interlocking device is very useful and simple for consisting of manual source-changeover system.

DESCRIPTION	CIRCUIT BREAKERS	POLE
MIT03	UTE100	3
MIT23	UTS150/250	2 or 3
MIT33	UTS400/600	2 or 3
MIT53	UTS800/1200	3

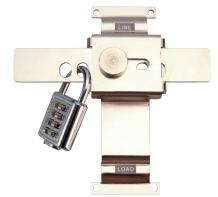

Mechanical Interlock

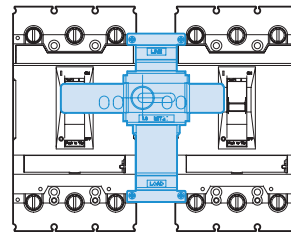
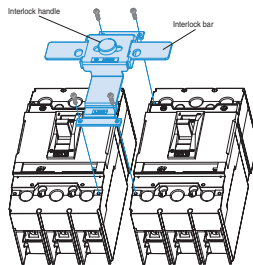

## ENCLOSURE DIMENSIONS OVERVIEW

The short circuit rating of an enclosed circuit breaker is equal to the rating of the circuit breaker installed, except as footnoted.

Circuit breakers are ordered and shipped separately for field installation

### ENCLOSURE DIMENSIONS

CIRCUIT BREAKER	AMPERAGE	ENCLOSURE DIMENSIONS (W X H X D) inch (mm)	
		80%	100%
UTE100	15~100A	8.27 (210) X 17.3 (439.4) X 4.0 (101.6)	
UTS150	40~150A	8.58 (218) X 18.11 (460) X 4.02 (102)	
UTS250	150~250A	12.13 (308) X 28.5 (724) X 5.35 (136)	
UTS400	250~400A	13.78 (350) X 40.16 (1020) X 5.98 (152)	13.78 (350) X 40.16 (1020) X 7.17 (182)
UTS600	500~600A	13.78 (350) X 40.16 (1020) X 5.98 (152)	14.17 (360) X 41.34 (1050) X 7.17 (182)
UTS800	400~800A	20.25 (514.4) X 51.9 (1318.3) X 7.75 (196.9)	
UTS1200	800~1200A	20.25 (514.4) X 51.9 (1318.3) X 7.75 (196.9)	23.0 (584.2) X 62.25 (1581.2) X 14.75 (374.7)

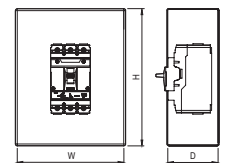

Enclosure Dimensions

## BUSBAR CONNECTIONS OVERVIEW

UTE100 and UTS250 frame circuit breakers may be equipped with captive nuts and screws for direct connection to bars.

Terminal plates are needed for replacement of lug connections with busbar connections. And to UTS400 from UTS1200 frame circuit breakers may be equipped without terminal plates.

### TERMINAL PLATE FOR BUSBAR CONNECTION OF UTE100, UTS150 AND UTS250 CIRCUIT BREAKERS

DESCRIPTION	CIRCUIT BREAKERS	TOOL	QTY PER KIT	TORQUE	
Terminal Plate,UTE100-3P	TP03	UTE100	+Driver	3	15.2 lb-in (1.72 N•m)
Terminal Plate,UTS150-3P	TP2a3	UTS150	+Driver	3	50 lb-in (5.64 N•m)
Terminal Plate,UTS250-3P	TP2b3	UTS250	Hex 1/4 inch	3	117.8 lb-in (13.3 N•m)

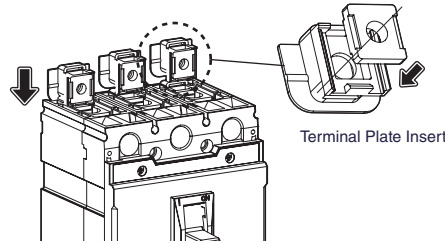
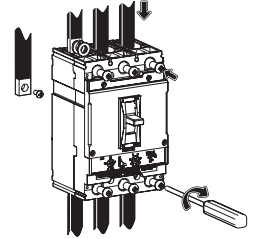

### BUSBAR DIMENSION OF TO UTE100 FROM UTS1200 CIRCUIT BREAKER

Dimensions: inch(mm)

CIRCUIT BREAKERS	A	B	C	D	E	F
UTE100	0.2(5.1)	0.08~0.28(2~7.2)	0.35(9)	0.32(8)	0.26(6.5)	-
UTS150	0.26 (6.5)	0.122~0.24 (3.1~6)	0.51~0.63 (13~16)	0.49 (12.5)	0.31 (8)	-
UTS250	0.33 (8.5)	0.122~0.31 (3.1~8)	0.51~0.79 (13~20)	0.98 (25)	0.31 (8)	-
UTS400	0.39 (10)	0.118~0.31 (3~8)	1.26 (32)	1.18 (30)	0.55 (14)	-
UTS600	0.39 (10)	0.118~0.47 (3~12)	1.26 (32)	1.18 (30)	0.55 (14)	-
UTS800	0.35 (9)	0.26~0.31 (6.5~8)	2.52 (64)	1.18 (30)	0.59 (15)	0.98 (25)
UTS1200	0.43 (11)	0.31~0.39 (8~10)	3.03 (77)	1.18 (30)	0.59 (15)	0.98 (25)

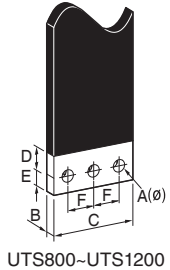
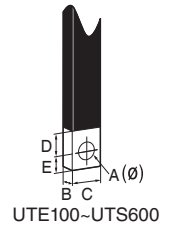

### CONTROL WIRE TERMINAL FOR MECHANICAL LUGS AND TERMINAL PLATE

Mechanical lugs may be equipped with a separate control wire terminal. The kit is available as a field installable kit. The adaptor is secured underneath the lug and has a tab extension suitable for attachment of a 1/4 inch slip-on connector.

Fully insulated type connectors must be used to prevent live parts from extending into the wiring gutter area.

DESCRIPTION	CIRCUIT BREAKERS	QTY PER KIT
Control wire terminal, CWT	UTE100	2
	Under 40A	
	Over 40A	
	UTS150	
	UTS250	
	UTS400	
UTS600		

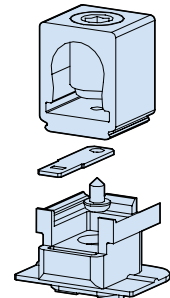

## BUSBAR CONNECTIONS

Fixed, front-connection busbars are equipped with terminals comprising captive screws for direct connection of bars. Other connection possibilities for bars include vertical-connection adapters for edgewise bars and spreaders to increase the pole pitch.

DESCRIPTION	CIRCUIT BREAKERS	POLE	QTY PER SET
SP02a	UTE100	2P	2
SP03a		3P	3
SP2a2a	UTS150	2P	2
SP2a3a		3P	3
SP2b2a	UTS250	2P	2
SP2b3a		3P	3
SP32a	UTS400	2P	2
SP33a	UTS600	3P	3
SP53a	UTS800 UTS1200		3
SP53e		3P	3
SP53v			3

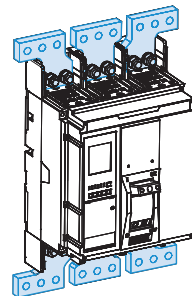

Busbar(a)

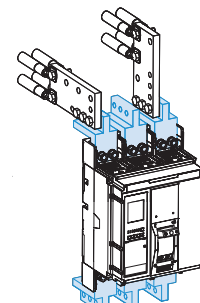

Extension Busbar(e)  
Vertical Busbars(v)

## INSULATION BARRIER

These barriers are insulated between the phases for increase insulation level. The barriers can be easily installed, even on breakers that are already mounted, by inserting them into the corresponding slots. They are incompatible with both the insulating terminal covers.

It is possible to mount the phase separating partitions between two side by side circuit breakers.

DESCRIPTION	CIRCUIT BREAKERS	POLE	QTY PER SET
B03	UTE100	3P	4
B23	UTS150	3P	4
	UTS250		
B33	UTS400	3P	4
	UTS600		
B53	UTS800	3P	2
BE53	UTS1200		2

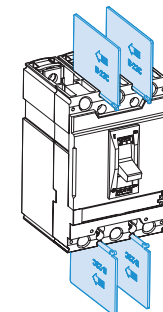

Standard Type

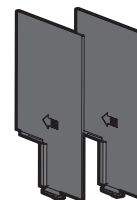

Standard Type(B53)

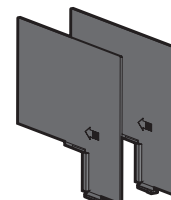

Extended Type(BE53)

# HANDLES

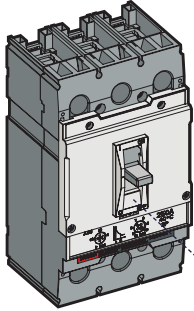

Molded Case Circuit Breaker  
Motor Circuit Protector  
Molded Case Switch

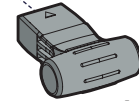

Aux. Handle

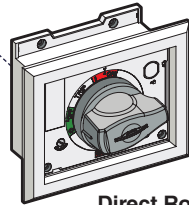

Direct Rotary Handle

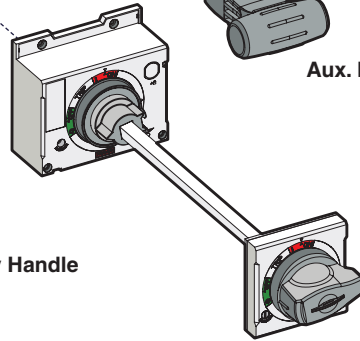

Extended Handle

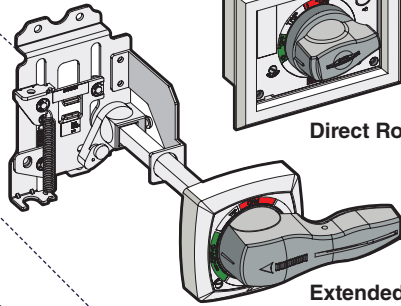

Extended Handle

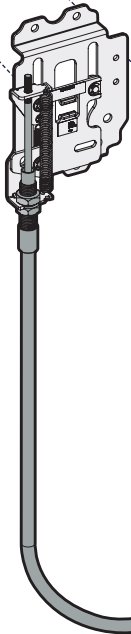

Flange Cable Handle

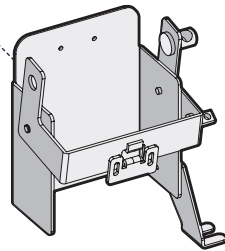
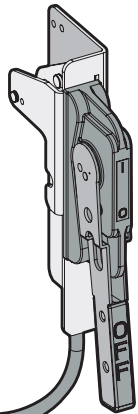

Operating Mechanism (VDM/COM)

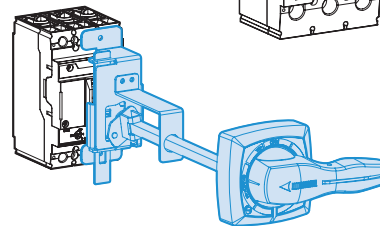
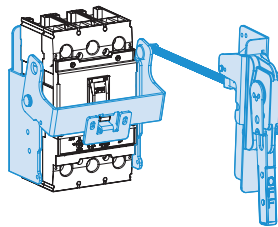
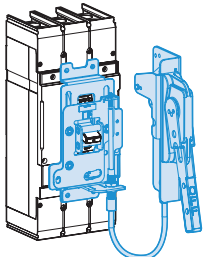
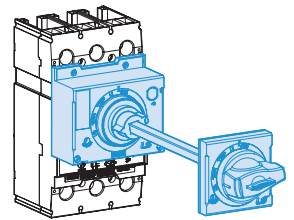
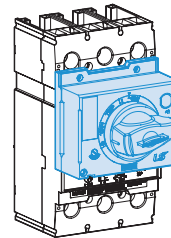

## HANDLE MECHANISMS OVERVIEW

All kinds of handles are suitable for field installation in LS molded case circuit breakers, molded case switches and motor circuit protectors. These are directly mounted rotary, door mounted and flange handles for installation of above noted products for 2 and 3 poles. In case of extended rotary handle, Base lower case assembly should be installed to circuit breaker, Handle should be mounted on panel door and they are interconnected by shaft. In case of flange mounting rotary handle, Base lower case assembly should be installed to circuit breaker, Handle should be mounted on panel door and they are connected by cable.

### CONSTRUCTION DETAIL:

#### Corrosion Protection:

All iron and steel parts are protected against corrosion by painting or equivalent means.

**Handle indication Making:** The following making are provided

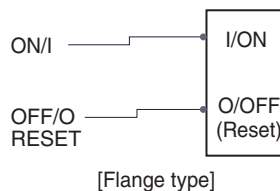
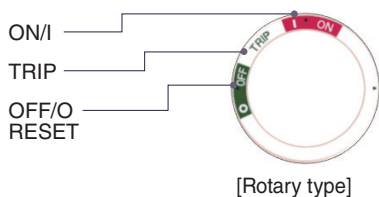

#### CAUTION Markings:

The following markings are provided:



## SELECTION FOR HANDLES

### • Catalog Numbering [Product Selection]

**EHU**

**0**

**12**

DESCRIPTION		MODEL SIZE PER CIRCUIT BREAKER FRAME		SHAFT & CABLE SIZE PER HANDLES	
<b>EHU</b>	Extended Hatndle (Type 1,12)	<b>0</b>	100AF (for all type)	<b>12</b>	12inch (Shaft)
<b>EHV</b>	Extended Handle (Type 3,3R,4)	<b>0C</b>	100AF (for all type & Compact base)	<b>16</b>	16inch (Shaft)
<b>EHX</b>	Extended Handle (Type 3,4,4X)	<b>2</b>	150/250 AF (for all type)	<b>24</b>	24inch (Shaft)
<b>FHU</b>	Flange Mounting Handle (Type 1, 12, 3, 3R, 4)	<b>3</b>	400/600 AF (for all type)	<b>36</b>	36inch (Cable)
<b>FHX</b>	Flange Mounting Handle (Type 4, 4X)	<b>5</b>	800/1200 AF (for all type)	<b>48</b>	48inch (Cable)
<b>REH</b>	Extended Rotary Handle (Type 1)	<b>S</b>	Standard Type (for Flange handle)	<b>60</b>	60inch (Cable)
<b>DH</b>	Direct Rotary Handle(Type 1)	<b>L</b>	Long type (for Flange handle)	<b>72</b>	72inch (Cable)
<b>DHK</b>	Direct Rotary Handle Keylock type(Type 1)			<b>84</b>	84inch (Cable)
<b>VDM</b>	Variable Depth Mechanism			<b>128</b>	128inch (Cable)
<b>COM</b>	Cable Operating Mechanism			<b>BLANK</b>	No type

## APPLICATION FOR HANDLES

Handle mechanisms are used to operate molded case circuit breakers, molded case switches and motor circuit protectors. They are available in three basic configurations-Directly mounted, Door mounted and Flange mounted for providing safe, easy installation and dependable operation.

OPERATION HANDLE TYPE NAME	APPLIED TO UL489 MCCB/MCS	
	CIRCUIT BREAKER & SWITCH	TYPE
EHU0-12-24 EHV0-12-24 EHX0-12-24 EHU0C-12-24 EHV0C-12-24 EHX0C-12-24 REH0-12-24 REH0C-12-24 DH0 VDM0, FHU-S VDM0, FHX-S COM0, FHU-S COM0, FHX-S	MCCB	UTE100 (100AF, 2 or 3Pole)
EHU2-12-24 EHV2-12-24 EHX2-12-24 FHU2-36-72 FHX2-36-72 REH2-12-24 DH2 DHK2 VDM2, FHU-S VDM2, FHX-S COM2, FHU-S COM2, FHX-S	MCCB MCP      MCS	UTS150 (150AF, 2 or 3 Pole)   UTS250 (250AF, 2 or 3 Pole)   UTS150 (150AF, 3 Pole)  UTS250 (250AF, 3 Pole)
EHU3-12-24 EHV3-12-24 EHX3-12-24 FHU3-36-72, 128 FHX3-36-72, 128 REH3-12-24 DH3 DHK3 VDM3, FHU-L VDM3, FHX-L COM3, FHU-L COM3, FHX-L	MCCB MCP      MCS	UTS400 (400AF, 2 or 3 Pole)   UTS600 (600AF, 2 or 3 Pole)   UTS400 (400AF, 3 Pole)  UTS600 (600AF, 3 Pole)
EHU5-12-24 EHV5-12-24 EHX5-12-24 FHU5-60-128 FHX5-60-128 REH5-12-24 DH5 DHK5 VDM5, FHU-L VDM5, FHX-L COM5, FHU-L COM5, FHX-L	MCCB MCP      MCS	UTS800 (800AF, 3 Pole)   UTS1200 (1200AF, 3 Pole)   UTS800 (800AF, 3 Pole)  UTS1200 (1200AF, 3 Pole)

**MCCB:** Molded Case Circuit Breaker

**MCP:** Motor Circuit Protector

**MCS:** Molded Case Switch

## ROTARY OPERATING HANDLES

### DIRECTLY MOUNTED ROTARY OPERATING HANDLE

The directly mounted rotary operating handle replaces the circuit breaker front accessory cover. When using UTE100, front cover does not have to be replaced.

The direct rotary handle maintains:

- Suitability for isolation
- Indication of three positions: I (ON), Tripped and O (OFF)
- Access to the “push-to-trip” button
- Visibility of, and access to, trip unit settings
- The circuit breaker may be locked in the ON/OFF position by using padlock (not supplied)

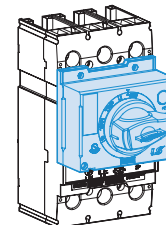

Directly Mounted Rotary Operating Handle

### MODELS

- Standard with dark gray handle
- Field installable (secured by screws)

UTE 100	UTS150/250	UTS 400/600	UTS 800/1200
DH-0	DH-2	DH-3	DH-5

- Field installable with Key lock (secured by screws)

UTS150/250	UTS400/600	UTS800/1200
DHK-2	DHK-3	DHK-5

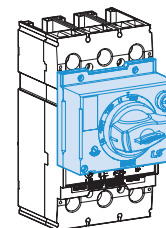

Directly Mounted Rotary Operating Handle with key lock.

Accessories transform the standard direct rotary handle for the following situations:

- Opening of door prevented when circuit breaker is on
- Closing of circuit breaker inhibited when door is open

### STANDARDS

The directly-mounted rotary operating handle is UL Listed under file E223241  
Degree of protection NEMA Type 1

## ROTARY OPERATING HANDLES

### EXTENDED (DOOR-MOUNTED) ROTARY OPERATING HANDLE

The extended rotary operating handle replaces the front accessory cover of the circuit breaker (secured by screws). When using UTE100, front cover does not have to be replaced.

The extended rotary operating handle consists of:

- A handle assembly with front plate on the door that is always secured in the same position, whether the circuit breaker is installed vertically or horizontally
- An adjustable extension shaft
- The handle mechanism can be used in NEMA Type 1 enclosure applications

The extended rotary operating handle makes it possible to operate circuit breakers installed in enclosure from the front.

- Suitability for isolation
- Indication of the three positions OFF (O), ON (I) and tripped
- Visibility of and access to trip unit settings when the door is open
- Degree of protection: NEMA Type 1
- Defeatable interlock prevents opening of door when circuit breaker is on

The circuit breaker may be locked in the off position by using padlock, padlock shackle diameter 0.2~0.3 inch(5~8mm); padlocks are not supplied; locking prevents opening of the enclosure door

#### MODELS

- Standard with dark gray handle
- Field installable (secured by screws)

UTE 100		UTS150/250	UTS 400/600	UTS 800/1200
REH-0	REH-0C	REH-2	REH-3	REH-5

The shaft length is the distance between the back of the circuit breaker and the door:

- Minimum mounting depth is 5.51 in. (140 mm) in UTE100
- Minimum shaft length is 12 in. (305 mm) with standard shaft
- Maximum shaft length is 24 in. (600 mm) with long shaft
- Extended shaft length must be adjusted

#### STANDARDS

The door-mounted rotary operating handle is UL Listed under file E223241  
Degree of protection NEMA Type 1

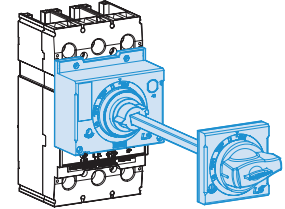

Door-Mounted Rotary Operating Handle (REH-0, 2, 3, 5)

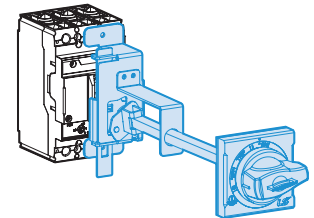

Door-Mounted Rotary Operating Handle (REH-0C)

## NEMA DOOR-MOUNTED ROTARY OPERATING HANDLE

The extended rotary operating handle consists of:

- A mounting plate that provides a rotary actuator for a standard toggle circuit breaker
- Handle assemblies available for NEMA Type 1, 12, 3, 3R, 4, 4X
- Available in standard or long (12~24 in.) handle assemblies

The door mounted operating handle makes it possible to operate circuit breakers installed in enclosure from the front.

- Indication of three positions: I (ON), Tripped and O (OFF) : NEMA Type 1, 12
- Provides ON (I) and OFF (O) indication : NEMA Type 3, 3R, 4, 4X
- The circuit breaker may be locked in the ON/OFF position

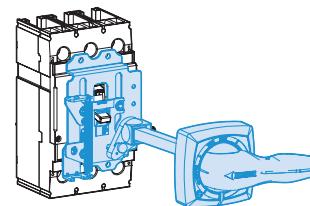

Door Mounted rotary operating handle  
[EHU, V, X-0, 2, 3, 5]

### MODELS

- Standard with dark gray handle(NEMA Type 1, 12)
- Out door with black handle(NEMA Type 3, 3R, 4, 4X)
- Field installable (secured by screws)

UTE100		UTS150/250	UTS 400/600	UTS 800/1200
EHU-0	EHU-0C	EHU-2	EHU-3	EHU-5
EHV-0	EHV-0C	EHV-2	EHV-3	EHV-5
EHX-0	EHX-0C	EHX-2	EHX-3	EHX-5

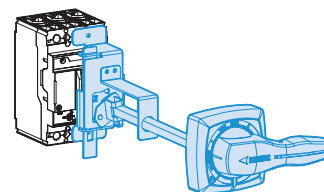

Door Mounted rotary operating handle  
[EHU, V, X-0C]

The shaft length is the distance between the back of the circuit breaker and door:

- Minimum mounting depth is 5.51 in. (140mm) in UTE 100
- Minimum shaft length is 12 in. (305mm) with long shaft
- Minimum shaft length is 24 in. (600mm) with long shaft
- Extended shaft length must be adjusted

### STANDARDS

The door-mounted rotary operating handle is UL Listed under file E223241  
Degree of protection NEMA Type 1, 12, 3, 3R, 4, 4X

## FLANGE HANDLE

### FLANGE HANDLE WITH SLIDING OPERATING MECHANISM

Flange handle with sliding operating mechanism is for use with cable

The cable operator maintains:

- Suitability for isolation
- Indication of two positions: O (OFF) and I (ON)
- The circuit breaker may be locked in the off position by one to three padlocks
- Door can be locked closed due to interlocking features of the handle operator
- Operating Mechanism has one type
  - Cable operating type with sliding mechanism

Handle is mounted on flange of enclosure using specified mounting dimensions while circuit breaker and operating mechanism are mounted to inside of enclosure using screws

- Handles are available in FHU (NEMA Type 1, 12, 3, 3R, 4) and FHX (NEMA Type 4, 4x)
- All circuit breaker operating mechanisms are suitable for right-hand flange mounting on the job.

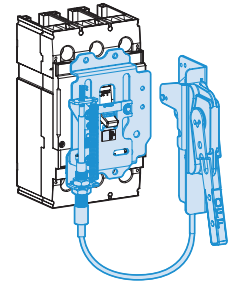

Flange handle with sliding operating mechanism and Cable [FHU-2, FHX-2]

### MODELS

- Standard with painted handle (NEMA Type 1, 12, 3, 3R, 4)
- Out door with nickel plating handle (NEMA Type 4, 4X)
- Field installable (secured by screws)

UTE100	UTS150/250	UTS 400/600	UTS 800/1200
-	FHU-2 FHX-2	FHU-3 FHX-3	FHU5 FHX5

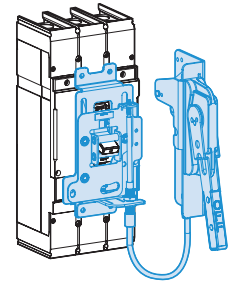

Flange handle with sliding operating mechanism and Cable [FHU-3, FHX-3]

FHU : Standard type handle (NEMA Type1, 12, 3, 3R, 4) with sliding mechanism and without cable

FHX : Outdoor type handle (NEMA Type 4, 4X) with sliding mechanism and without cable

Cable : Only cable

- Cable lengths available in 36~128 in. to UTS1200 from UTS150 lengths to accommodate a variety of mounting locations

### STANDARDS

Flange cable operating handle is UL Listed under file E223241

NEMA Type 1, 12, 3, 3R, 4, 4X

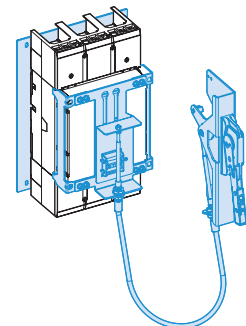

[FHU-5, FHX-5]

## FLANGE-MOUNTED CABLE OPERATING MECHANISM

Flange-mounted handle cable operating mechanism is for use with FH or COM Type handle operators especially designed for tall, deep enclosures where placement flexibility is required.

The cable operator maintains:

- Suitability for isolation
- Indication of two positions: O (OFF) and I (ON)
- The circuit breaker may be locked in the off position by one to three padlocks
- Door can be locked closed due to interlocking features of the handle operator
- Operating Mechanism has one type
  - COM : Cable operating type with handle operator
- Handle operators (FHU, FHX)

Handle is mounted on flange of enclosure using specified mounting dimensions while circuit breaker and operating mechanism are mounted to inside of enclosure using screws

- Handles are available in COM and FHU NEMA Type 1, 12, 3, 3R, 4 and FHX NEMA Type 4, 4x
- All circuit breaker operating mechanisms are suitable for right-hand flange mounting on the job.
- COM frame operating mechanism does not include cable.

### MODELS

- Standard with painted handle(NEMA Type 1, 12, 3, 3R, 4): FHU
- Out door with nickel plating handle(NEMA Type 4, 4X): FHX
- Field installable (secured by screws)

UTE100	UTS150/250	UTS400/600	UTS800/1200
FHU-S	FHU-S	FHU-L	FHU-L
FHX-S	FHX-S	FHX-L	FHX-L
COM-0	COM-2	COM-3	COM-5

FHU-S, FHX-S : Standard type handle with operating mechanism  
 FHU-L, FHX-L : Long type handle with operating mechanism  
 COM : Cable operating mechanism with handle and without cable  
 Cable : only cable

### CABLE TYPE

CABLE LENGTHS [inch]	UTE100 UTS150 UTS250	UTS400 UTS600	UTS800 UTS1200
36	FH2-36	FH3-36	-
48	FH2-48	FH3-48	-
60	FH2-60	FH3-60	FH5-60
72	FH2-72	FH3-72	-
84	-	-	FH5-84
128	-	FH3-128	FH5-128

### STANDARDS

Flange cable operating handle is UL Listed under file E223241  
 NEMA Type 1, 12, 3, 3R, 4, 4X

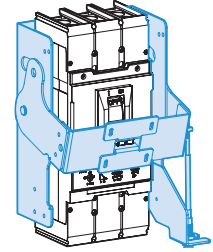

Cable Operating Mechanism without Handle and cable



Flange Handle [FHU, X-S, L]

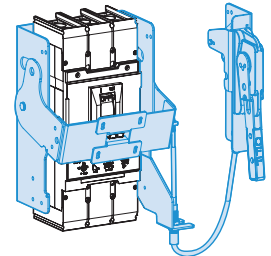

Handle with cable and Cable operating mechanism [COM-0, 2, 3, 5]

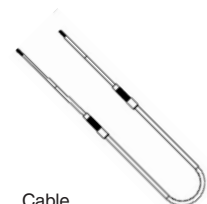

Cable [FH2, 3, 5-36~128]

# FLANGE HANDLE

## FLANGE-MOUNTED VARIABLE DEPTH OPERATING MECHANISM

Designed for installation in custom built control enclosures where main or branch circuit protective devices are required.

The variable depth operator maintains:

- Suitability for isolation
- Indication of two positions: O (OFF) and I (ON)
- The circuit breaker may be locked in the off position by one to three padlocks
- Door can be locked closed due to interlocking features of the handle operator
- Operating Mechanism has one type
  - VDM : Variable depth type with handle operator
- Handle operators(FHU, FHX)
- Threaded-rod has only one type

Handle is mounted on flange of enclosure using specified mounting dimensions while circuit breaker and

operating mechanism are mounted to inside of enclosure using screws

- Handles are available in VDM and FHU NEMA Type 1,12, 3, 3R, 4 and FHX NEMA Type 4, 4x
- All circuit breaker operating mechanisms are suitable for right-hand flange mounting on the job.
- VDM frame operating mechanism includes handle operator.

### MODELS

- Standard with painted handle(NEMA Type 1,12,3,3R,4)
- Out door with nickel plating handle(NEMA Type 4, 4X)
- Field installable(secured by screws)

UTE100	UTS150/250	UTS400/600	UTS800/1200
FHU-S	FHU- S	FHU-L	FHU-L
FHX-S	FHX- S	FHX-L	FHX-L
VDM-0	VDM-2	VDM-3	VDM-5

FHU-S, FHX-S : Standard type handle with operating mechanism

FHU-L, FHX-L : Long type handle with operating mechanism

VDM : Variable depth operating mechanism with threaded-rod and handle.

The variable mounting depth length is the distance between the back of the circuit breaker and the door:

- VDM frame variable mounting depth range: 8.0~21.26 in (203-540 mm).
- Threaded-rod length : 16 in. (406 mm)

### STANDARDS

Flange variable depth operating handle is UL Listed under file E223241

NEMA Type 1, 12, 3, 3R, 4, 4X

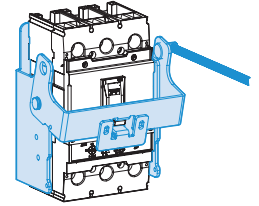

Variable-Depth operating Mechanism with Threaded-rod

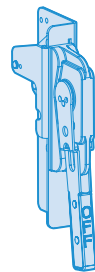

Flange Handle [FHU, X-S, L]

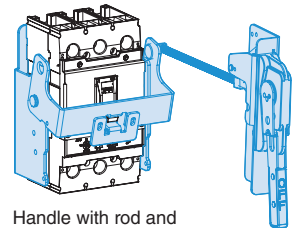

Handle with rod and Variable-Depth operating Mechanism [VDM-0, 2, 3, 5]

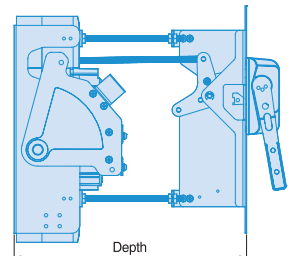

Variable mounting depth range

## REMOTE OPERATION

### MOTOR OPERATOR

Motor operators can be operated manually. The motor drives a mechanism which switches UTS toggle handle to the “ON” and “OFF/RESET” positions.

- The manual actuator handle is located on the front of the cover.
- Manual or Automatic operation can be selected.
- Applicable to 2, 3pole breakers.
- Door can be locked closed due to interlocking features of the handle operator
- Operating Mechanism has one type
  - Cable operating type with sliding mechanism



MOP2U-L



MOP3U-L

The motor operator is an essential device for constructing a remote operated automatic source-changeover system to ensure a continuous supply of electrical power at following certain installations:

- Commercial sector: Hospital, Tall building, Bank, Insurance companies, Shopping centers
- Industry: Ships, Assembly lines at plant, Military sites, Port and Railway installation

MCCB	Type	Control voltage (V)	Actuation current (A)	Response time (ms)		Consumption (W)	Mechanical service life (operations)	No. of operations per hour	Remarks
				Closing	Opening				
UTS150, 250	MOP2U	DC 24V	≤2.5A	350	230	14	25,000	120	Lock function
	MOP2U-L	AC 110V/DC 110V	(DC 24V)						
UTS400, 600	MOP3U	DC 24V	≤2.5A	500	350	35	20,000	60	Lock function
	MOP3U-L	AC 110V/DC 110V	(DC 24V)						

### WIRING CONNECTION

#### Standard connection

Circuit breaker On and Off controlled by remote operation and manual operation

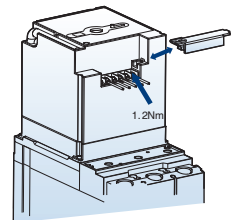
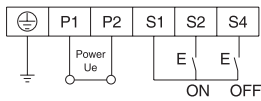

#### Connection with alarm switch (AL)

- 1) The below connection diagram is the method of using a alarm switch (AL) without shunt or undervoltage trip.
- 2) After clearing the fault surely, manual reset is mandatory in case of tripping due to an electrical fault.

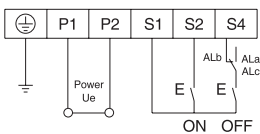

### MANUAL OPERATION

- 1) Insert the manual handle into the slot of Motor Operator surface and rotate it clockwise.
- 2) It must be rotated just 180° clockwise for safe operation of micro switch in the motor operator.
- 3) Return the manual handle after the manual operation
- 4) Turn the slide switch back to the position of AUTO.

**CAUTION:** When the circuit breaker is tripped by trip button in the OFF status, it is impossible to operate motor operator automatically. It must be reset by manual operation.

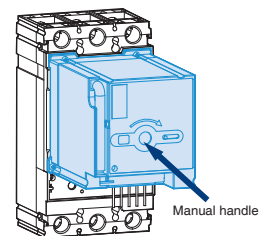

## REMOTE OPERATION

### AUTOMATIC OPERATION

- 1) Set the slide switch to AUTO, then internal power is closed automatically.
- 2) Operating frequency should be less than these below regulated values.  
 UTS150N/H/L , UTS250N/H/L: 120 operations per hour  
 UTS400N/H/L, UTS600N/H/L: 60 operations per hour
- 3) Use the ON/OFF switch in the range of regulated values.
- 4) It may interfere near communication equipments because of internal switching power supply.  
 It's recommended that a noise filter be installed to power supply.
- 5) Please do not input ON/OFF signals at the same time during the automatic operation.
- 6) If the circuit breaker has a UVT attached inside, charge a UVT on the rated voltage before performing MOTOR OPERATOR.

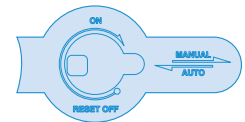

[UTS150, 250]

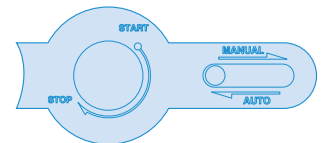

[UTS400, 630]

### MOTOR OPERATOR

#### Feature

- ① On position indication (Red color)
- ② Trip position indication (White color)
- ③ Off position indication (Green color)
- ④ Button for push to trip  
(available for only for UTS400AF and UTS600AF)
- ⑤ On/Off/Reset selection lever
- ⑥ Manual/Auto selection lever

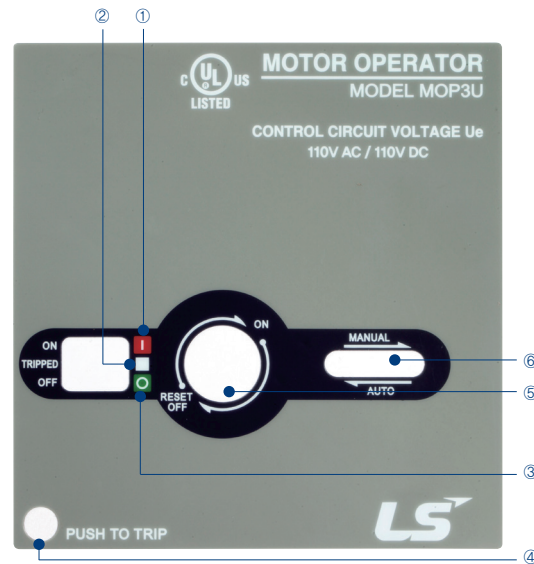

#### UTS150, 250 .... MOP2U



#### UTS400, 630 .... MOP3U

